

cast iron gate valve

Outside Screw and Yoke • Rising Stem • Solid Wedge
Option: Zinc Free Bronze Trim • Indicator • Resilient Wedge •
Epoxy Coated Body • Stainless steel Trim

BS5150 PN16

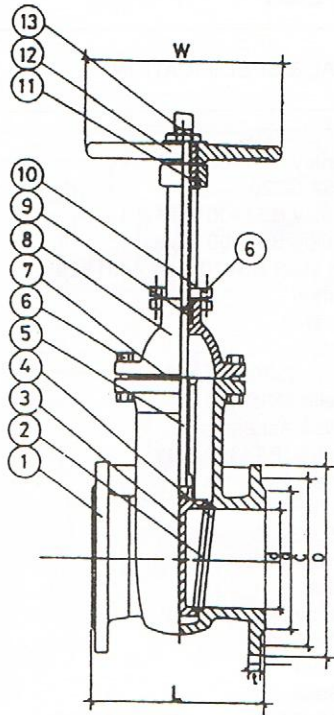

F-620-FN

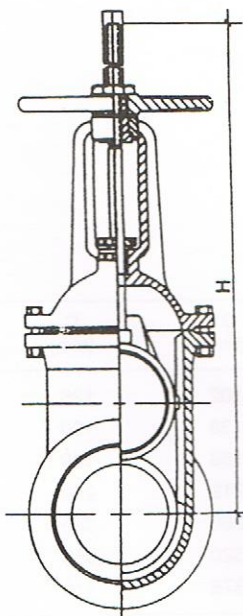

MATERIAL LIST

PART	MATERIAL	SPECIFICATION (BS)
1. Body	Cast Iron	1452 GRADE 220
2. Body Seat Ring	Gunmetal	1400 LG2
3. Wedge	Cast Iron	1452 GRADE 220
4. Wedge Ring	Gunmetal	1400 LG2
5. Stem	Stainless Steel	970 Part 4 Grade 302S25
6. Hexagon Nut/Bolt	18-8 Stainless Steel	--
7. Gasket	Rubber	--
8. Bonnet	Cast Iron	1452 Grade 220
9. Gland Packing	Asbestos Free	--
10. Gland	Cast Iron	1452 Grade 220
11. Stem Nut	18-8 Stainless Steel	--
12. Handwheel	Cast Iron	1452 Grade 220
13. Lock Nut	Steel	--

Note: Materials conform to BS

Flanges to BS4504 PN16

Maximum work pressure: 10 bar - 25 bar (Size to be specified)

Operating temperature : -10°C to 120°C

DIMENSIONS

Nominal Size d	L (mm)	Flange BS4504 PN16					H (mm)
		D (mm)	C (mm)	g (mm)	t (mm)	f (mm)	
50mm	178	165	125	102	20	3	413
65mm	190	185	145	122	20	3	441
80mm	203	200	160	138	22	3	498
100mm	229	220	180	158	24	3	603
125mm	254	250	210	188	26	3	689
150mm	267	285	240	212	26	3	789
200mm	292	340	295	268	30	3	1020
250mm	330	405	355	320	32	3	1226
300mm	356	460	410	378	32	4	1445
350mm	381	520	470	438	36	4	1460
400mm	406	580	525	490	38	4	1497
450mm	510	640	585	532	40	4	1497
500mm	540	715	650	585	42	4	1647
600mm	600	840	770	685	48	5	1949
700mm	660	910	840	800	54	5	2254
800mm	720	1025	950	905	58	5	2560
900mm	780	1125	1050	1005	62	7	2900
1000mm	840	1255	1170	1115	66	7	3500
1200mm	960	1400	1340	1295	66	9	4000
1500mm	1140	1700	1630	1695	66	9	5100