



## STANDARD CLEVIS HANGER Fig : SS 40

The Clevis Hanger provides a vertical adjustment of approximately 2 inches after pipe is in Place.

The lower nut adjusts pipe line to the proper pitch and the top nut when locked into position prevents loosening due to vibration .

The nuts are not included in the price of hanger. Hangers for 18 inch pipe and larger are furnished with spreaders on The cross bolts.

**Approvals :** Underwriters Laboratories listed Factory Mutual approved for pipe sizes 2 " through 12 " .Complies with Federal Specification and Manufacturers Standardization

**Regularly furnished black. Galvanized or painted to order.**

**Order by size and figure number.**

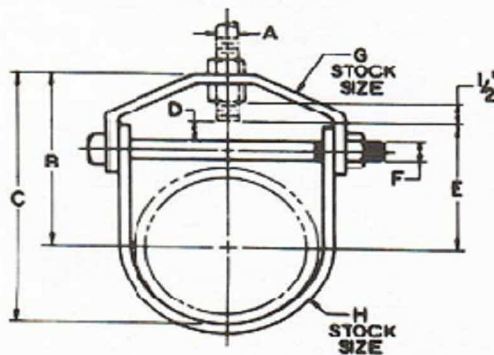

**STANDARD ADJUSTABLE  
CLEVIS HANGER**

### DIMENSIONS IN mm.

Pipe Size	Max.Recom Load , kg.	A	B	C	D	E	F	G	H	Weight per 100
2	273	9	120	170	20	100	9	5x32	4x32	64
2 1/2	500	13	125	170	20	111	9	5x32	4x32	110
3	500	13	135	190	25	123	9	5x32	4x32	120
4	637	16	157	220	25	140	10	5x32	4x32	205
5	637	16	168	245	30	153	10	5x40	5x40	285
6	864	19	190	280	30	175	10	5x40	5x40	370
8	909	22	230	345	50	218	13	5x47	5x47	510
10	1637	22	295	430	65	275	13	5x47	510	880
12	1728	22	332	495	76	315	20	7x50	880	1150
14	1910	25	365	540	90	345	20	7x50	1150	1480
16	2182	25	425	615	105	405	25	7x65	6x65	2100
18	2182	28	450	680	115	433	25	7x65	6x65	2435
20	2182	31	490	745	125	469	30	10x80	9x80	4255
24	2182	31	535	855	125	525	30	10x80	9x80	4850